

Safety Message to Installers of Warning Light Equipment

⚠ WARNING

People's lives depend on your proper installation and servicing of Federal Signal products. It is important to read and follow all instructions shipped with this product and the original product. Listed below are some other important safety instructions and precautions you should follow:

- To properly install the lighting system, you must have a good understanding of automotive systems, along with proficiency in the installation and use of safety warning equipment.
- Do not install equipment or route wiring in the deployment path of an airbag.
- If a vehicle seat is temporarily removed, verify with the vehicle manufacturer if the seat needs to be recalibrated for proper airbag deployment.
- When drilling into a vehicle structure, be sure that both sides of the surface are clear of anything that could be damaged.
- Refer to the instructions packed with related products for additional precautions and information.
- This product contains high-intensity LEDs. Do not stare directly into the light at close range or permanent damage to your eyesight may occur.
- For the light to function properly, a separate ground connection must be made. If practical, it should be connected to the negative battery terminal. At a minimum, it may be attached to a solid metal body or chassis part that will provide an effective ground path as long as the light system is to be used.
- To avoid damage the light, ensure that the input voltage is the same voltage as the voltage rating of the light. Ensure that the correct polarity is observed and that the beacon is properly fused.
- Locate the light control so the VEHICLE and CONTROL can be operated safely under all driving conditions.
- Do not attempt to activate or deactivate light control while driving in a hazardous situation.
- You should frequently inspect the light to ensure that it is operating properly and that it is securely attached to the vehicle.
- File these instructions in a safe place and refer to them when maintaining and/or reinstalling the product.

Failure to follow all safety precautions and instructions may result in property damage, serious injury, or death.

Product Overview

The Firebolt® beacon is equipped with LEDs for zero light maintenance with no bulbs or strobe tubes to replace. The combination of long-lasting LEDs, advanced dome optics and high-intensity flash patterns eliminate dark spots or shadows around the beacon. The beacon includes a black polycarbonate base and 14 selectable “strobing” flash patterns and a test pattern. The Firebolt meets SAE J845 Class 2 requirements.

Unpacking the Beacon

After unpacking the beacon, inspect it for damage that may have occurred in transit. If it has been damaged or is missing a part, do not attempt to install or operate it. File a claim immediately with the carrier, stating the extent of the damage. Carefully check all envelopes, shipping labels and tags before removing or destroying them. If you are missing any parts, contact Customer Support at 1-800-264-3578 or 1-708-534-3400 7 a.m. to 5 p.m., Monday through Friday (CT).

⚠ WARNING

AIRBAG DEPLOYMENT—Do not install equipment or route wiring in the deployment path of an airbag. Failure to observe this warning will reduce the effectiveness of the airbag or potentially dislodge the equipment, causing serious injury or death.

⚠ WARNING

LIGHT HAZARD—To be an effective warning device, an emergency warning system produces bright light that can be hazardous to your eyes at close range. Do not stare into the light at close range or permanent damage to you eyesight may occur.

NOTICE

REVERSE POLARITY MISWIRING—Reverse polarity or incorrect voltage may damage the beacon. To avoid damage, ensure that the battery voltage is the same as the voltage rating of the light and that the correct polarity is observed. If you are connecting to a 12 V power outlet, connect the positive wire to the center terminal and connect the negative wire to the outer terminal.

Surface Mounting the Beacon

NOTICE

DRILLING PRECAUTIONS—Before drilling holes, check the area into which you are drilling to be sure that you do not damage vehicle components. De-burr all drilled holes and smooth all sharp edges. Protect all wires routed through drilled holes with convolute/split-loom tubing.

IMPORTANT: Before you begin the installation, plan all wire routing.

To mount the beacon permanently on the vehicle surface:

1. Select a mounting location for the beacon.
2. See Figure 1. Using the base of the beacon as a template, scribe mounting hole locations on the mounting surface. Scribe a wire routing hole location on the mounting surface. Orient the drain slot (Figure 2 on page 3) to minimize its exposure to wind driven rain and moisture.

Figure 1 Firebolt dimensions

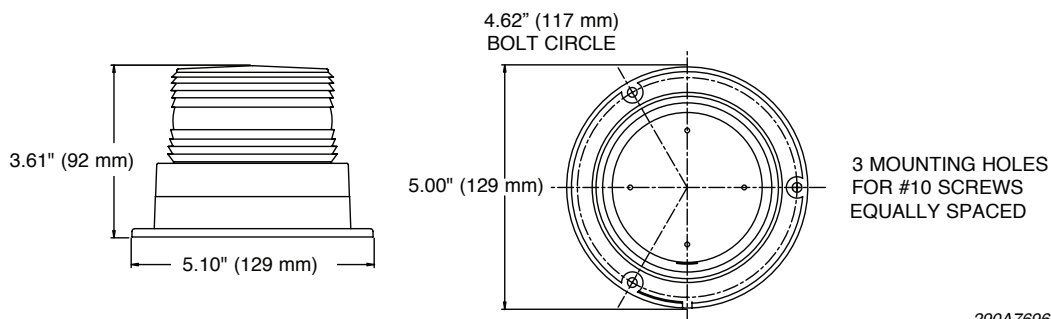

3. Drill three 0.203" holes at the scribed mounting hole locations. Drill a 0.31" hole at the scribed wire routing hole location. Remove all burrs and sharp edges.
4. Install the supplied grommet in the wire routing hole.
5. Center the gasket over the drilled holes and route the wires through the gasket and grommet.

Figure 2 Beacon mounting and wiring

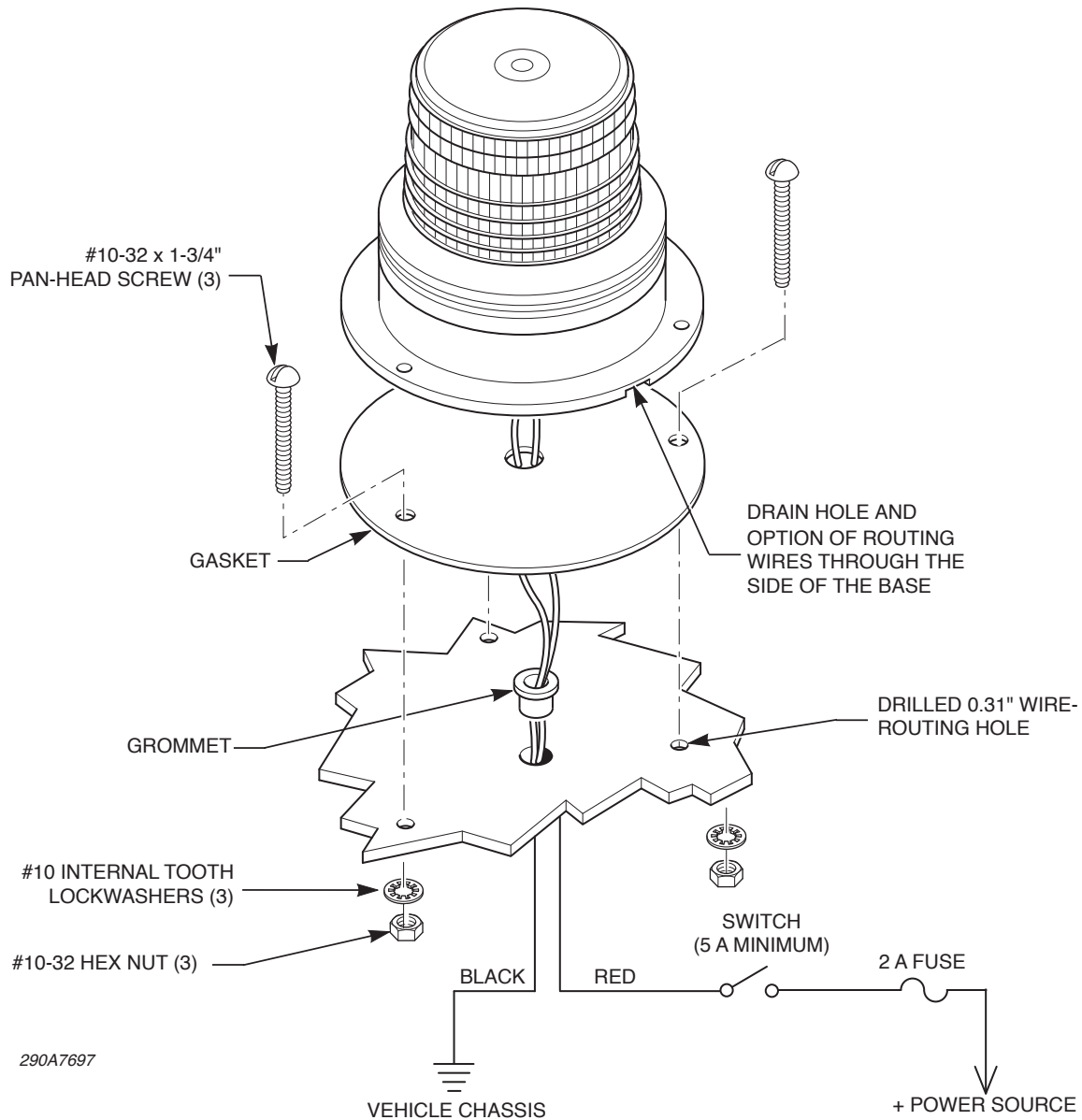

Wiring the Surface-Mounted Beacon

To wire the beacon:

1. Determine the length of wires needed for the installation. For lengths up to 15 ft (5 m), use minimum 18 AWG (1 mm²) wire. For lengths over 15 ft, use minimum 16 AWG (1.5 mm²) wire.
2. Strip 1/4 inch (5 mm) of insulation from the ends of the red and black installer-supplied wires.

Installation and Flash Pattern Selection Instructions

3. Connect one terminal of an installer-supplied switch with a current capacity of at least 5 A to the red (+) wire of the beacon. Additional 18 AWG (1 mm²) or larger wire may be added, if needed.
4. Use 18 AWG (1 mm²) or larger wire to connect the remaining switch terminal to one end of the supplied fuseholder and 2 A fuse.
5. Connect the other end of the fuseholder to the positive (+) terminal of the voltage source.
6. Connect the black (-) wire from the beacon to a known good vehicle ground as close to the beacon as practical.
7. Test the beacon for proper operation.

Magnetic Mounting

⚠ WARNING

DO NOT DRIVE WITH MAGNETICALLY-MOUNTED BEACON INSTALLED—Because vehicle roof construction and driving conditions vary, do not drive a vehicle with a magnetically-mounted beacon installed. The beacon could fly off the vehicle causing injury or damage. Repair of damage incurred because of ignoring this warning shall be the sole responsibility of the user.

The holding power of magnetic mounting systems is dependent upon surface finish, surface flatness, and thickness of the steel mounting surface. Therefore, to promote proper magnetic mounting:

- ✓ Ensure that the mounting surface is flat.
- ✓ The mounting surface and magnets must be kept clean, dry, and free of foreign particles that prevent good surface contact.
- ✓ A magnet mounting system should not be used on vehicles with vinyl tops.
- ✓ To prevent the sliding of the beacon on the mounting surface, avoid quick acceleration and hard stops.

To temporarily mount the beacon to a vehicle with a magnetic mounting system:

1. Place the beacon on the vehicle roof at a location that provides maximum signaling effectiveness for your application.
2. To operate the magnet-mounted beacon, insert the plug at the end of the cable assembly into the 12 V power outlet socket.
3. Test the beacon for proper operation.

Pipe Mounting and Wiring the Beacon

The base was designed for the option of installing the beacon onto the end of a threaded 1/2-inch NPT pipe.

1. Determine the length of wires needed for the installation. For lengths up to 15 ft (5 m), use minimum 18 AWG (1 mm²) wire. For lengths over 15 ft, use minimum 16 AWG (1.5 mm²) wire.
2. Strip 1/4 inch (5 mm) of insulation from the ends of the red and black installer-supplied wires.
3. Use insulated butt connectors to connect the red and black wires of vehicle electrical system to the red and black wires of the beacon. Ensure that the connectors are securely crimped and properly insulated.

4. Route the red and black wires through the pipe to the location of the installer-supplied switch (current capacity of at least 5 A).
5. Screw the beacon onto the pipe. Ensure that the wires are not pinched inside the pipe.
6. Connect one terminal of the installer-supplied switch to the red (+) wire of the beacon.
7. Use minimum 18 AWG (1 mm²) wire to connect the remaining switch terminal to one end of the supplied fuseholder and 2 A fuse.
8. Connect the other end of the fuseholder to the positive (+) terminal of the voltage source.
9. Connect the black (-) wire from the beacon to a known good vehicle ground as close to the beacon as practical.
10. Test the beacon for proper operation.

Figure 2 Pipe-mounted beacon

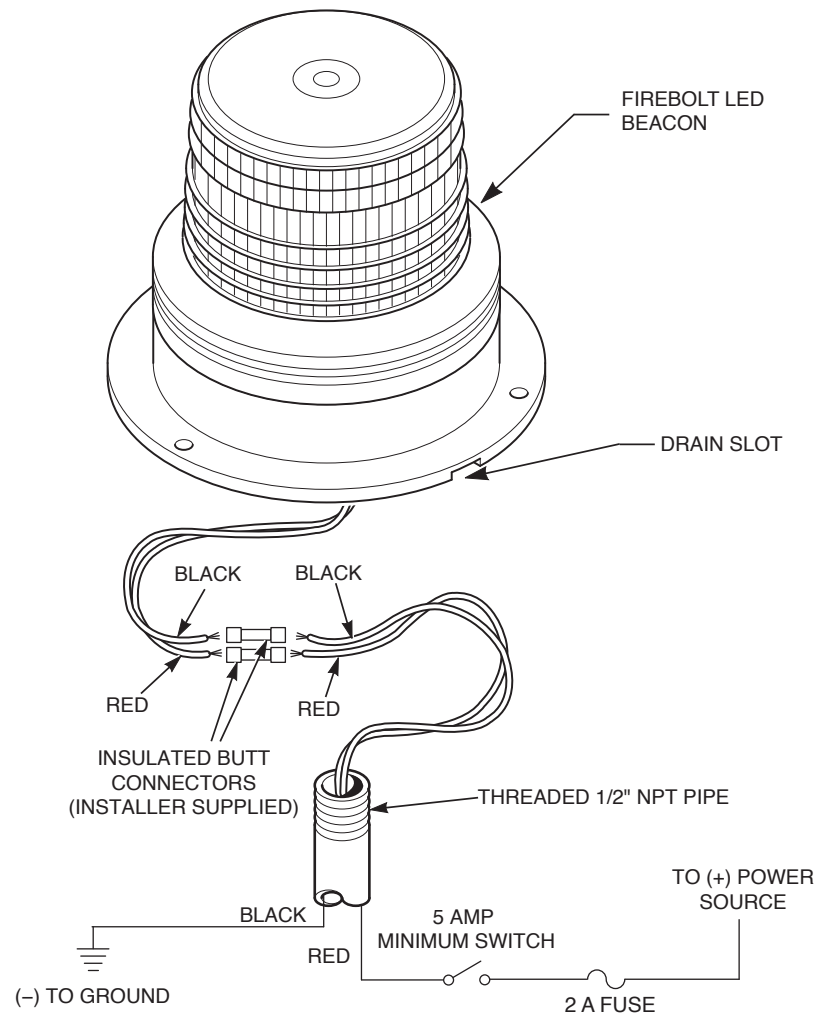

290A7698

Selecting a Flash Pattern

The flash patterns shown in Table 2 are selected by cycling the power switch at a once-per-second pace. If you wait too long the beacon ignores the request to enter programming mode. The beacon also ignores a quick flick of the switch, therefore the switch must stay closed for a minimum of 1/10 of a second to register. There is a 15-second window of time to watch the pattern and change it again before the beacon automatically exits programming mode.

To select a flash pattern:

1. Turn the power on/off three times, once per second, to enter programming mode.
2. While in the programming mode, cycle the switch off and on to advance the active pattern to the next in the sequence.
3. When you see the pattern that you want, allow the beacon to operate for a minimum of 15 seconds, or turn it off for more than five seconds to exit programming mode and to set the pattern in memory.

Table 2 Flash patterns

Pattern	Description	Rate (FPM)
1	4 Single, 2 Quad	120-60
2	7X Flash	65
3	Chopped Double	60
4	Single Flash	60
5	Single Flash	80
6	Single Flash	120
7	Test	—
8	Double Flash	80
9	Double Flash	120
10	Triple Flash	60
11	Triple Flash	120
12	Pulsing Double Flash	80
13	Quad Flash	60
14	Pulsing Quad Flash	60
15	5X Flash	75

Getting Technical Support and Service

For technical support and service, please contact:

Federal Signal Corporation

Service Department

Public Safety Systems

Phone: 1-800-433-9132, 1-708-534-3400

Fax: 1-800-343-9706

Email: empserviceinfo@fedsig.com

(7 a.m. to 5 p.m., Monday through Friday, Central Time)

Cleaning the Dome

⚠ WARNING

CRAZING/CHEMICALS—A crazed, cracked or faded dome reduces the light output and the effectiveness of the lighting system. A dome showing this type of aging must be replaced. Failure to follow this warning may result in bodily injury or death.

⚠ WARNING

CRAZING/CLEANING SOLUTIONS—The use of cleaning solutions, such as strong detergents, solvents, and petroleum products, can cause crazing (cracking) of the dome. Failure to follow this warning can damage the dome, reducing the light output and the effectiveness of the lighting system. Failure to follow this warning may result in bodily injury or death.

To clean the dome:

1. Rinse the dome with lukewarm water to loosen dirt and debris.
2. Use a mild soap, lukewarm water, and a soft cloth to gently clean the dome. Do not use heavy pressure or caustic, abrasive, or petroleum-based cleaners.
3. Rinse and dry the dome with a soft cloth to prevent water spotting.

Ordering Replacement Parts

To order replacement parts, please contact your local dealer/distributor or:

Customer Support

Federal Signal Corporation

Phone: 1-800-264-3578, 1-708-534-3400

(7 a.m. to 5 p.m., Monday through Friday, Central Time)

Returning a Product to Federal Signal

Before returning a product to Federal Signal, call (1-800-264-3578) or 1-708-534-3400 to obtain a Returned Merchandise Authorization number (RMA number) (7 a.m. to 5 p.m., Monday through Friday, Central Time).

To expedite the process please be prepared with the following information:

- Your Federal Signal customer or account number.
- The purchase order number under which the items were purchased.
- The shipping method.
- The model or part number of the product being returned.
- The quantity of products being returned.
- Drop ship information as needed.
- Any estimate required.

When you receive your RMA Number:

- Write the RMA number on the outside of the box of returned items.

Installation and Flash Pattern Selection Instructions

- Reference the RMA number on your paperwork inside of the box.
- Write the RMA number down, so that you can easily check on status of the returned equipment.

Send all material with the issued RMA Number to:

Federal Signal Corporation
2645 Federal Signal Drive
University Park, IL 60484-3167
Attn: Service Department
RMA: # _____



2645 Federal Signal Drive, University Park, IL 60484-3167
Tel.: (800) 264-3578 • Fax: (800) 682-8022
www.fedsig.com